



FS14-80x80-G520-M-CLR-S

LED Four-side lighting
for Machine Vision



520
nm

Made in GERMANY © evotron 2019-05

Product Properties

The LED four-side lighting FS14 consist of four swivelling line lights. This makes it easy to set up complex lighting scenes quickly and easily. The patented swivel mount prevents a migration of the light sources during the rotation, thus eliminating time-consuming adjustment work. The integrated **Light Sensor Processor - LSP** guarantees high precision and long-term stability of the lighting parameters.

- Homogeneous, bright object illumination due to integrated optics
- Impact resistant Corning® Gorilla® Glass cover
- Setting the illumination angle from 0° to 180°
- Simple and fast setup
- Integrated **Light Sensor Processor – LSP**
 - Auto Calibration - Monitoring Brightness
 - Monitoring the current LED temperature
 - High reliability, long life
- Active reverse polarity protection
- Integrated ESD protection
- Compact, robust, ready to install – Plug & Play
- Flash operation with 10-time overcurrent
- Operation with standard lighting controllers
- Protection rating – IP67

Dimensions

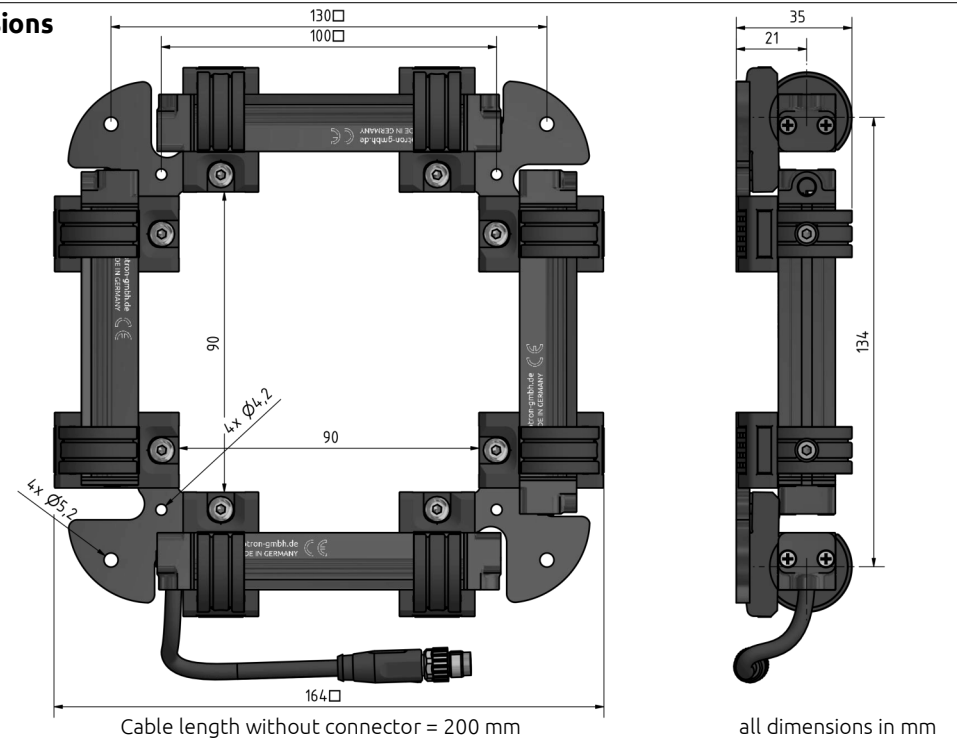

evotron GmbH & Co. KG
Pfütschbergstraße 16
98527 Suhl / Germany

+49 (0) 3681-4529950
support@evotron-gmbh.de
www.evotron-gmbh.de

Disposal

This product is RoHS compliant. This product may be returned to the manufacturer for proper disposal.

The product itself must not be disposed of in the domestic waste.



WEEE-Reg.-Nr. DE85473784

Functional Overview

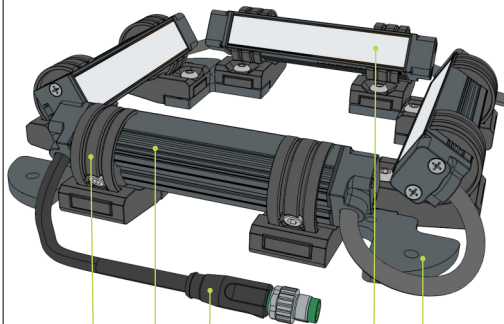

- 1 Swivel holder adjustable 0° ... 180°
- 2 LED lighting modules
- 3 Robotics connection cable with M8 plug
- 4 Illuminated fields with glass cover
- 5 Mounting bracket with mounting hole

Technical Data

LED-Colour, Wavelength	Green, 520 nm		
Radiation Angle	30° / 0° ... 180°		
Optical Material	Glass		
Dimension Light Field (B x L)	14 mm x 80 mm		
Dimension Housing (H x B x L)	164 mm x 164 mm x 35 mm		
Housing Material	Aluminium / PA12		
Weight	346 g		
Protection Rating	IP 67		
Protection Class	III, Safety Extra Low Voltage (SELV)		
Risk Group (DIN EN 62471)	Free Group		
Thermal Protection T _{MAX}	85 °C		
Plug type	M8-male, 4-pins		

Continuous Operation	Min	Nom	Max
LED-Current	0 A	480 mA	480 mA
LED-Forward Voltage	-	13.2 V	15.2 V
Power Consumption	0 W	6.3 W	7.3 W

Flash Mode	Min	Nom	Max
LED-Current	0 A	-	6.4 A
LED-Forward Voltage	-	-	24.0 V
Power Consumption @ Pulse (t _{PULSE} 100 µs)	0 W	-	153.6 W

Intended Use

This LED lighting is intended solely for use in the field of industrial automation technology, laboratory metrology and industrial image processing.

The permissible ambient conditions for the transport, assembly and operation of the module must be observed.



Safety Notes

Operate this LED lighting only in perfect, undamaged condition.

Configure the application so that the LED lighting is always within its technical specification.

Improper installation can damage the LED lighting.

Installation, assembly and commissioning must be carried out by qualified personnel.



Risk of injury from flickering, glare or radiation

Flickering, glare and stroboscopic effects can cause psychological disorders such as headache, discomfort or fatigue.



Risk of glare

A strong glare effect may cause a temporary reduction in eyesight, which may cause irritations or accidents.



Risk of burns due to hot surfaces

The lighting surface can reach a housing temperature of greater than 55 °C during operation. Do not cover or touch the lighting during operation.

Mounting

The mounting of the module takes place via the four mounting holes of the at the corners arranged mounting brackets. M5 Screws or optionally M4 screws can be used.

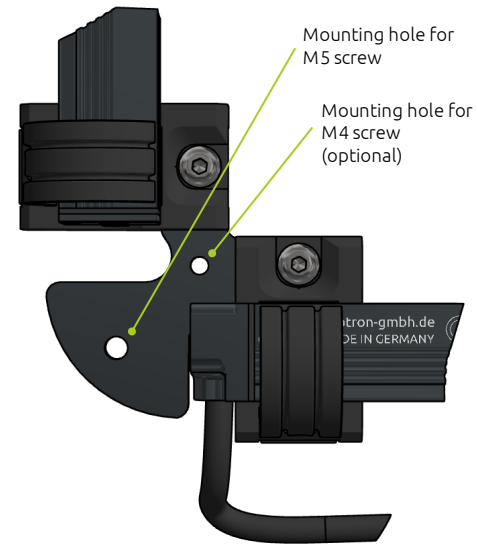

Adjustment of the illumination angle

The illumination angle of the 4 LED lighting modules can be adjusted with the integrated swivel holders in the range of 0 ° to 180 °. The rotational movement is absolute invariant to the light axis. The rotation takes place exactly around the centre of the light source.

1

Loosen the two clamping screws A with 2 left turns.

2

Rotate the LED lighting B to the desired position.

3

Tighten the two clamping screws A again.

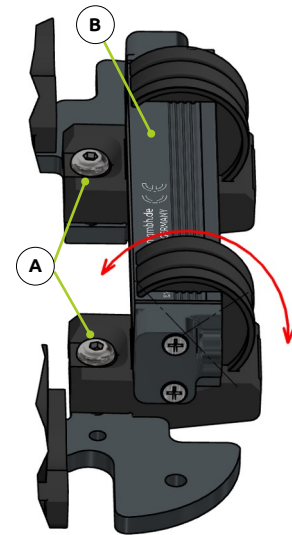

Required tool:
Allen key 2.5 mm

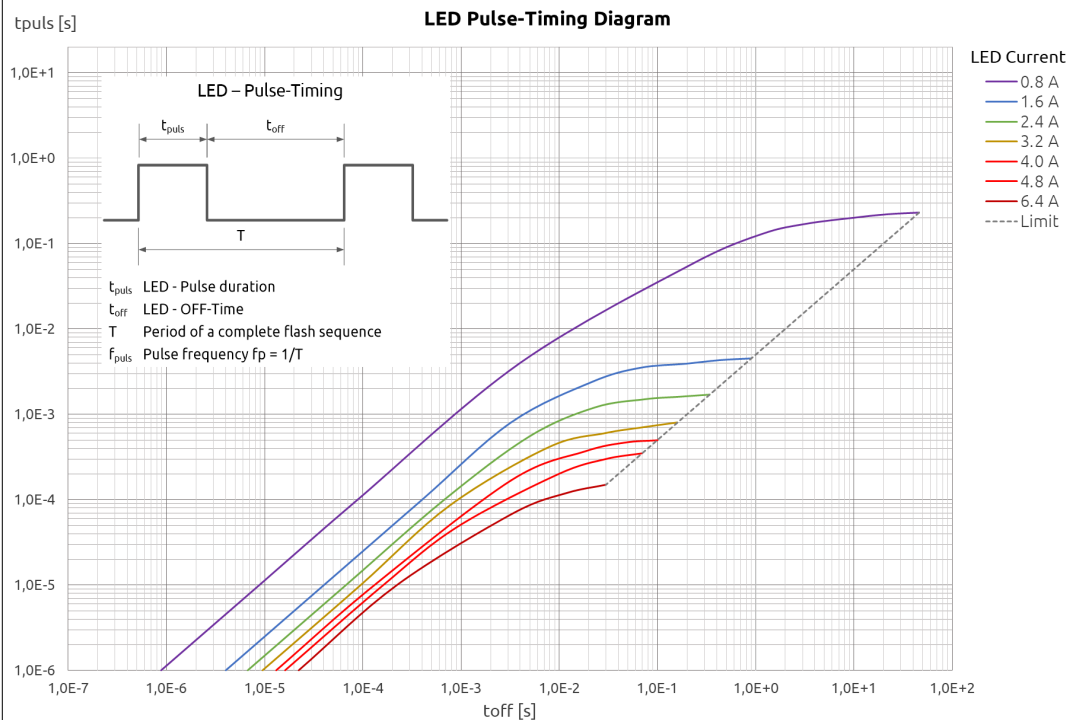

Putting into operation

Continuous light

Operate the LED lighting only with the parameters specified in the table Technical Data.

Flash Mode

In flash mode, the lighting can be pulsed with a multiple overcurrent.

From the *LED Pulse-Timing Diagram*, the required minimum OFF-Time t_{off} can be read directly for the selected flash duration t_{puls} .

1. Select flash pulse duration t_{puls} on the Y-axis
2. Select the desired LED current curve
3. Read t_{off} at the intersection on the X-axis
4. The maximum possible flash frequency f_{puls_max} is calculated by

$$f_{puls_max} = 1 / (t_{puls} + t_{off})$$

Protection Functions

The active polarity reversal protection prevents damage to the LED lighting when the connections are reversed.

Cleaning

For the glass surface, use a cleaner suitable for optical components.

Connection Plan

The LED lighting must be controlled with a suitable current source.

All evotronLIGHT lighting controllers or other commercially available LED controllers with a controlled current output are suitable for operation.

Pin Assignment M8 male 4-pin

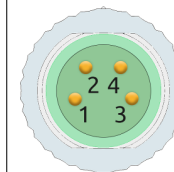

PIN 1	Brown	+LED
PIN 2	White	SD *
PIN 3	Blue	-LED
PIN 4	Black	SG *

* These pins are only used by LED-lighting controllers with evotronLIGHT technology – otherwise do not connect.

IMPORTANT NOTICE



Do not connect the LED lighting directly to a 24V power source or to any power supply.